



LEDVANCE HIGH VOLTAGE BATTERY SYSTEM

Installation and Operation
Instructions

LES-HV-4K



CONTENT

Important information in the manual.....	1
Scope	1
Description of LES-HV-4K	1
Meaning of symbols.....	2
General safety information.....	4
Disclaimer.....	4
Proper use.....	5
Safety.....	6
Safety rules.....	6
Safety information.....	6
Scope of Delivery.....	7
LES-ESS and LES-HV Base package.....	7
LES-HV-4K battery package.....	8
Battery system introduction.....	9
Operating panel.....	10
Number of battery modules supported by LES-HV-4K	11
Installation	12
Installation place requirement.....	12
Tools requirement.....	13
Installation steps.....	13
Product installation steps.....	14
Selection of installation sites.....	16
Definition of interface.....	16
Batteries in parallel.....	17
Single battery system.....	17
Commissioning.....	18
Switch on the battery system.....	18
Light meaning.....	19
Switch off the battery system.....	19
Safety design.....	20
Electrical Schematic Diagram.....	20
Wi-Fi DISTRIBUTION NETWORK.....	23
Maintenance and storage.....	28
Cleaning.....	29
Storage.....	31
Disposal.....	32
Fault and solution.....	33

IMPORTANT INFORMATION IN THE MANUAL

Scope

This installation and operation manual applies to the stackable battery energy storage system. Please carefully read this manual guide installation, preliminary debugging, and maintenance of LES-HV-4K. Installation, preliminary debugging, and maintenance must be carried out by qualified and authorized engineer. Please keep this installation and operation manual and other applicable documents near the battery energy storage system, so that all engineer involved in installation or maintenance can access this installation and operation manual at any time.

Description of LES-HV-4K

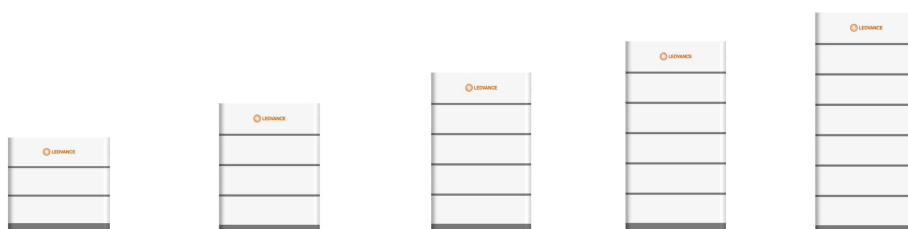

Module	LES-HV-4K 204.8V 8.2K	LES-HV-4K 307.2V 12.3K	LES-HV-4K 409.6V 16.4K	LES-HV-4K 512V 20.5K	LES-HV-4K 614.4V 24.6K
Battery module number	2	3	4	5	6
Nominal voltage (V)	204.8	307.2	409.6	512	614.4
Operating voltage (V)	179.2-233.6	268.8-350.4	358.4-467.2	448-584	537-700.8
Nominal capacity (Ah)	40				
Nominal energy (kWh)	8.192	12.288	16.384	20.48	24.576
Available energy (kWh)	7.373	11.059	14.746	18.432	22.118
Recommended discharge current(A)	20				
Max discharge current (A)	40				
Max charge current (A)	40				
Discharge rate	1C				
Depth Discharge (%)	90%				
Discharge temperature (°C)	-18~58				
Charge temperature (°C)	2~48				
Warranty period	10 years				

IMPORTANT INFORMATION IN THE MANUAL



Terminal	MC4				
Communication	CAN 2.0/RS485/WiFi/Bluetooth				
SOC display	5LED (20% , 40% , 60% , 80% , 100%)				
install	Floor mount				
Dimension W*D*H (mm)	600*400*560	600*400*730	600*400*900	600*400*1070	600*400*1240
Battery module(kg)	37				
High voltage control box(kg)	13.5				
Battery module base(kg)	4.5				
Weight (kg)	92	129	166	203	240
Humidity	5%~95%RH				
Altitude (m)	≤2000				
IP Rating of Enclosure	IP65				
Certificate	IEC 62619/EMC/UN38.3/CE				
Extensibility	Up to 8 systems can be used in parallel				

Meaning of Symbols

This manual contains the following types of warnings:



Danger! It may cause an electric shock.

Even when the equipment is disconnected from the grid, the voltage-free state will have a time lag.



Danger! If the instructions are not observed, death or severe injury may occur.



Warning! If the instructions are not observed, a loss may occur.



Attention! This symbol represents information on the device use.

IMPORTANT INFORMATION IN THE MANUAL

The following types of warning, prohibition, and mandatory symbols is important.



Attention! The risk of chemical burns

If the battery is damaged or fails, it may lead to electrolyte leakage, which in turn causes the formation of a small amount of hydrofluoric acid, among other effects. Contact with these liquids can cause chemical burns.

- Do not subject the battery module to severe impact.
 - Do not open, disassemble or mechanically change the battery module.
 - In case of contact with an electrolyte, wash the affected area with clean water immediately and seek medical advice promptly.
-



Attention! The risk of explosion

Incorrect operation or fire may cause the lithium-ion battery unit to ignite or explode, leading to serious injury.

- Do not install or operate the battery module in explosive or high-humidity areas.
 - Store the battery module in a dry place within the temperature range specified in the datasheet.
 - Do not open, drill through or drop the battery cell or module.
 - Do not expose the battery cell or module to high temperatures.
 - Do not throw the battery cell or module into the fire.
 - If there is a fire from the battery, please use the CO2 extinguisher. If there is a fire near the battery, please use a dry powder extinguisher.
 - Do not use defective or damaged battery modules.
-



Caution! Hot surface

- If a malfunction occurs, the parts will become very hot, and touching them may cause serious injury.
 - If the energy storage system is defective, please shut it down immediately.
 - If the fault or defect becomes obvious, special care should be taken when handling the equipment.
-



No open fire!

It is prohibited to handle open flames and ignition sources near the energy storage system.



Do not insert any objects into the opening in the housing of the energy storage system!

No objects, such as screwdrivers, may be inserted through openings in the casing of the storage system.

IMPORTANT INFORMATION IN THE MANUAL



Wear safety goggles! Wear safety goggles when working on the equipment.



Follow the manual!

When working and operating the equipment, the installation and operation manual provisions must be observed.

General Safety Information



Danger! Failure to comply with the safety information can lead to life-threatening situations.

1. Improper use can cause death. Operators of LES-HV-4K must read this manual and observe all safety information.
2. Operators of LES-HV-4K must comply with the specifications in this manual .
3. This manual cannot describe all conceivable situations. For this reason, applicable standards and relevant occupational health and safety regulations are always given priority.
4. In addition, the installation may involve residual hazards in the following circumstances:
 - Incorrect installation.
 - The installation is carried out by personnel who did not receive relevant training or guidance.
 - Failure to observe the warnings and safety information in this manual.

If there are any questions, please contact LDV ESS after service.

Disclaimer

LDV POWER shall not be liable for personal injury, property loss, product damage and subsequent losses under the following circumstances.

- Failure to comply with the provisions of this manual.
- Incorrect use of this product.
- Unauthorized or unqualified personnel repair the product, disassembly the rack and perform other operations.
- Use of unapproved spare parts.
- Unauthorized modifications or technical changes to the product.

IMPORTANT INFORMATION IN THE MANUAL

Proper Use

- The battery energy storage system can only be installed and operated under the eaves or indoors. The working environment temperature range of LES-HV-4K is $-18^{\circ}\text{C} \sim 58^{\circ}\text{C}$, and the maximum humidity is 90%. The battery module shall not be exposed to the sun or placed directly beside the heat source.
- The battery module shall not be exposed to a corrosive environment.
- When installing the battery energy storage system, ensure that it stands on a sufficiently dry and flat surface with sufficient bearing capacity. Without the manufacturer's written approval, the installation site's altitude shall not be higher than 2,000 meters. The rated output power of the battery will decrease with the altitude.
- In areas where flooding may occur, care must be taken to ensure that the battery module is installed at a suitable height to prevent contact with water.
- The battery energy storage system must be installed in a fireproof room. This room must have no fire source and must be equipped with an independent fire alarm device, which complies with local applicable regulations and standards. Similar fire-proof requirements apply to other openings in the room (such as windows).

Compliance with the specifications in this manual is also part of proper use.

Requirements for Installation Personnel

All work shall comply with local applicable regulations and standards.

The installation of LES-HV-4K can only be completed by electricians with all following qualifications:

- Trained in dealing with hazards and risks associated with the installation and operation of electrical equipment, systems, and batteries.
- Trained on installation and debugging of electrical equipment.
- Understanding and complying with the technical connection conditions, standards, guidelines, regulations, and laws applicable.
- Knowledge of handling lithium-ion batteries (transportation, storage, disposal, hazard source).
- Understanding and complying with this document and other applicable documents.

SAFETY

Safety Rules

To avoid property damage and personal injury, the following rules shall be followed when working on the hazardous live parts of the battery energy storage system:

- It is available for use.
- Ensure that it will not restart.
- Make sure there is no voltage.
- Grounding protection and short circuit protection
- Cover or shield adjacent live parts.

Safety information

Part damage or short circuit may cause electric shock and death. A short circuit can be caused by connecting battery terminals, resulting in current flow. This type of short circuit shall be avoided under any circumstances. For this reason, follow these instructions:

- Use insulated tools and gloves.
- Do not put any tools or metal parts on the battery module or high-voltage control box.
- When operating the battery, be sure to remove watches, rings, and other metal objects.
- Do not install or operate this system in explosive or high-humidity areas.
- When working on the energy storage system, first turn off the charging controller, then the battery, and ensure that they are not turned on again.

Improper use of the battery energy storage system can lead to death. The use of the battery energy storage system beyond its intended use is not allowed, because it may cause great danger.

Improper handling of the battery energy storage system can cause life-threatening risks, serious injury or even death.



Warning! Improper use can cause damage to the battery cell.

- Do not expose the battery module to rain or soak it in liquid.
 - Do not expose the battery module to a corrosive environment (such as ammonia and salt).
 - The battery energy storage system shall be debugged no later than six months after delivery.
-

SCOPE OF DELIVERY

LES-HV-4K Base package



① LES-HV-4K (high voltage control box)

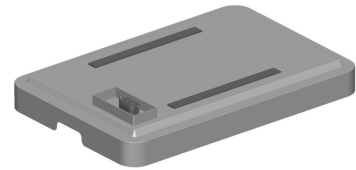

② LES-HV-4K Base x 1



③ 2M black external communication cable (RJ45 - M19)



④ 2M yellow-green grounding cable (8AWG)



⑤ 2M DC+ red external power cable (8AWG)



⑥ 2M DC- black external power cable (8AWG)



⑦ Bracket x 2

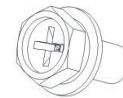

⑧ Screw (M4x4)



⑨ expansion bolt(m6x60)



⑩ WIFI antenna

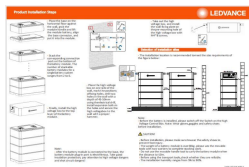

⑪ Fast loading manual



⑫ Product Manual



⑬ MC4-Evo 2 Unlock the tool

SCOPE OF DELIVERY

LES-HV-4K battery packge

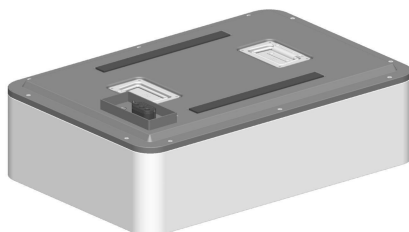

LES-HV-4K x 1

LES-HV-4K Base package	
①	High voltage control box (LES-HV-4K x1)
②	Battery base (LES-HV-4K Base x1)
③	2M black external communication cable (RJ45 – M19)
④	2M yellow-green grounding cable (8AWG)
⑤	2M DC+ red external power cable (8AWG)
⑥	2M DC- black external power cable (8AWG)
⑦	Bracket x 2 Used to fix products on walls
⑧	Screw (M4x4)
⑨	expansion bolt(M6x60)
⑩	WIFI antenna
⑪	Fast loading manual
⑫	Product Manual
⑬	MC4-Evo 2 Unlock the tool
LES-HV-4K package	
Battery module (LES-HV-4K x1)	

BATTERY SYSTEM INTRODUCTION

The Battery System LES-HV-4K is used as a connected battery for the intermediate storage of excess PV energy in an inverter system.

A	Operating Panel
B	LES-HV-4K (high voltage control box)
C	LES-HV-4K (battery module)
D	LES-HV-4K (battery base)
E	LED

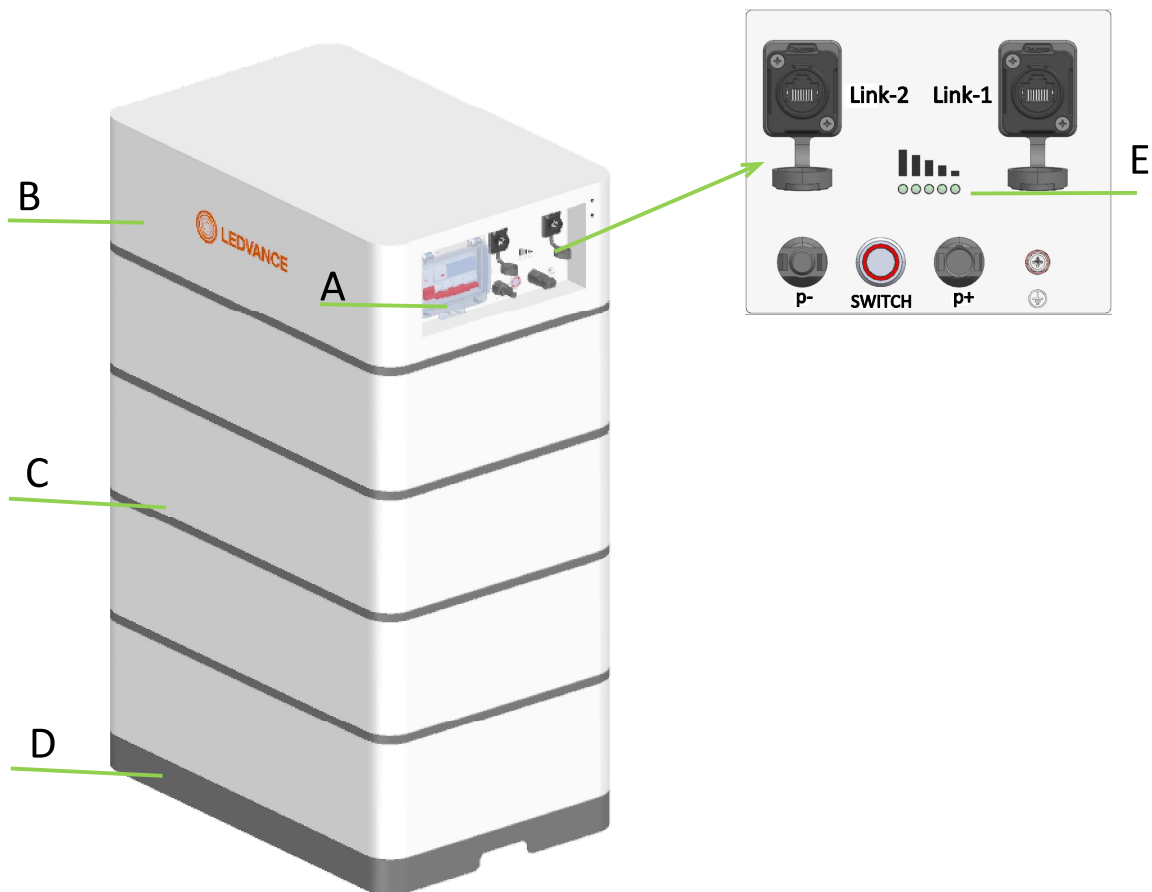

BATTERY SYSTEM INTRODUCTION

Operating Panel

1) Operating Panel 1 interview

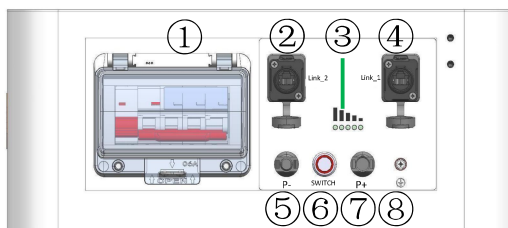

NO.	Name	Description
①	DC Breaker	High Voltage DC Breaker
②	Link_2	Communication Interface (For maintenance)
③	LED	SOC Display
④	Link_1	Communication Interface (To PCS)
⑤	P-	DC- Terminal
⑥	Switch	Black start switch
⑦	P+	DC+ Terminal
⑧	Grounding	/

2) Operating Panel 2 interview

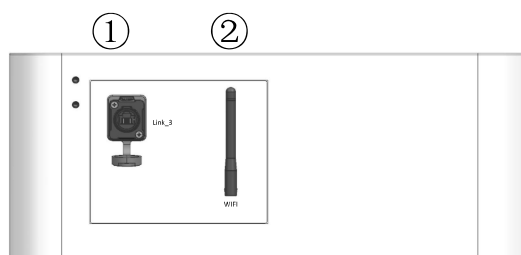

NO.	Name	Description
①	Link_3	Communication Interface (To other Batteries in parallel)
②	WIFI	WiFi antenna

BATTERY SYSTEM INTRODUCTION

Number of battery modules supported by LES-HV-4K

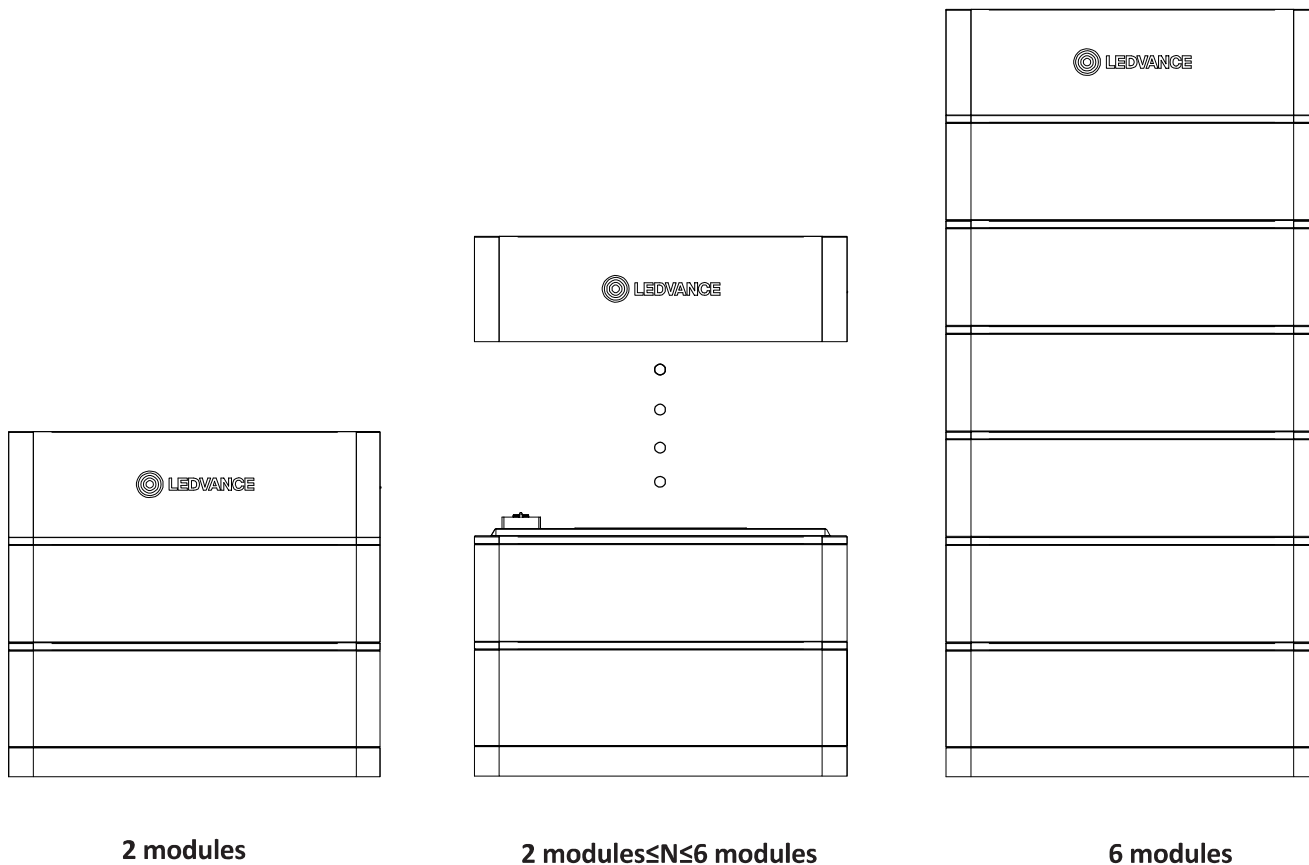

Note: Minimum two battery modules are required and Maximum Six modules in one parallel.

INSTALLATION

Installation Place Requirement

- ① Installed on the surface with enough dryness, horizontal and flat, and has sufficient carrying capacity. (For example, concrete or masonry).
- ② The altitude of the installation location must not be higher than 2000 meters. (The output power of the battery will decrease with the height of the altitude).
- ③ If in the flood area, you must pay attention to ensure that the battery is installed in an appropriate altitude to prevent contact with water.
- ④ Ensure there is no fire source, and it must be equipped with an independent fire alarm device.
- ⑤ Cannot be exposed to corrosive environments.
- ⑥ The working temperature range should be -18°C to 58°C .
- ⑦ The maximum environment humidity is 95%.
- ⑧ Can't be exposed to the sun or beside the heat source directly.
- ⑨ The installation site must be away from the children and the old.
- ⑩ The installation position must be compatible with the weight and size of the battery.

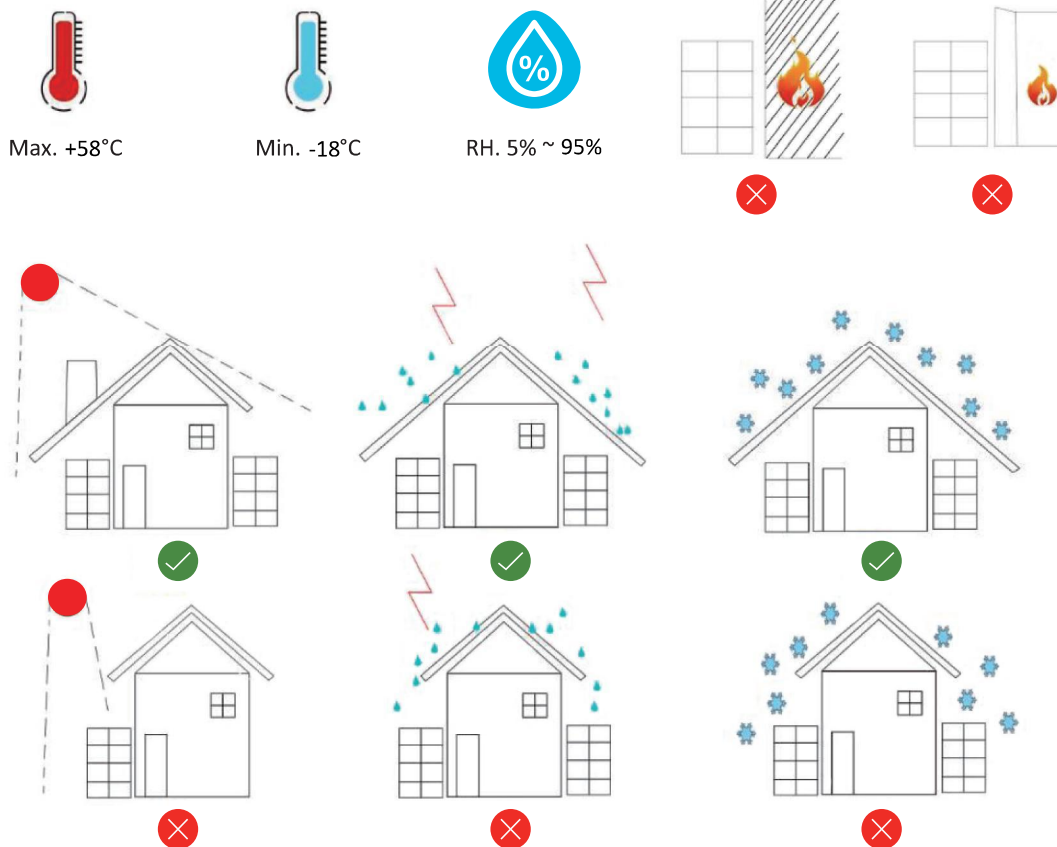

INSTALLATION

Tools Requirements:

1. When installing the battery system, wear the following safety equipment.



Gloves



Goggles



Safety Shoes

2. To install the battery system, you need the following tools



socket head wrench



External hexagonal wrench



electric drill

ATTENTION!

- Because the DC cable or connector on the battery system may cause electric shock or life threatening life, do not contact the end of the non-insulating cable.
- If the battery module incorrectly lifts or falls in the process of transportation or installation, it may cause the risk of injury due to the weight of the battery module.
- Carefully transport and lift the battery module. Consider the weight of the battery module.
- For those who work for the battery system, please wear qualified personal protection equipment.

Note: Before the battery is installed, please switch off the Switch on the high Voltage Control Box.

Note: Wear gloves, goggles and safety shoes before installation.

Installation steps



CAUTION!

- ① Before installation, please make sure to wear the safety shoes to prevent foot injury.
- ② The weight of a battery module is over 30kg. please use the movable tools with two workers to complete stacking work.
- ③ Do not use the movable handle tool to carry the battery module when the distance is $\geq 10\text{m}$.
- ④ Before using the transport tools, check whether they are reliable.
- ⑤ The installation humidity ranges from 5 % to 90 %

INSTALLATION

Product Installation Steps

- ① Take out the base and battery module. Place the base on hard floor, lift the battery module on top of the base using a movable handle tool.

CAUTION!



After the battery module is connected to the base, the battery module plug-in port is electriferous. Take good insulation protection, pay attention to high voltage dangers and shot circuit dangers!

- ② Stack the corresponding connection ports at the bottom of the battery module. The number of stackable battery modules for a single battery system ranges from 2 to 6.

- ③ Take out the high voltage box, and install the wall fixing plate on the pre-mounting hole of the high voltage box with M4*8 screws.

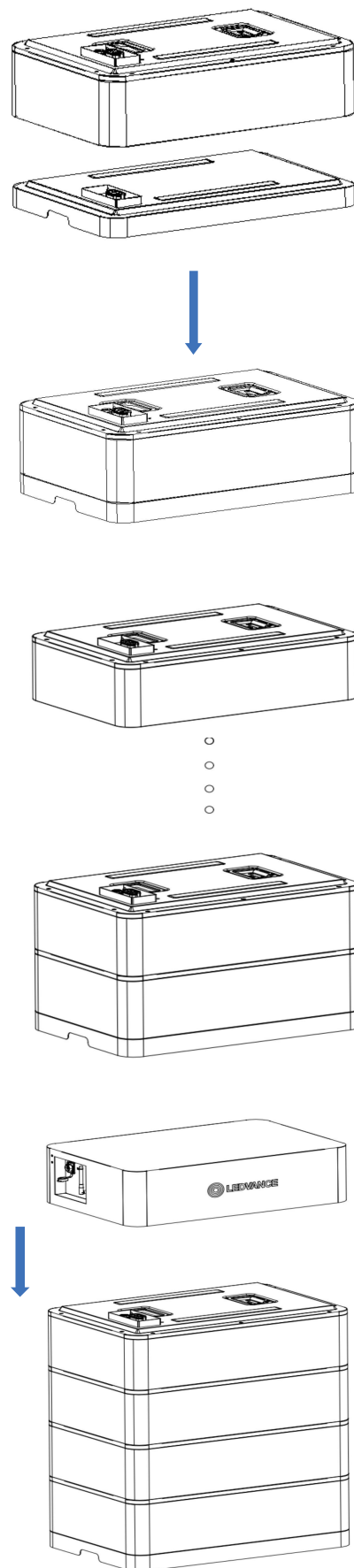

INSTALLATION

- ④ Finally, install the high voltage box to the top layer of the battery module.

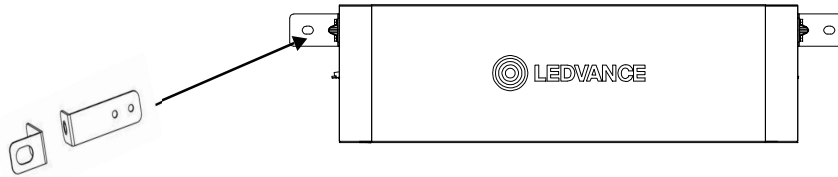

- ⑤ Place the high voltage box on one side of the wall, mark the positions of fixing holes, drill two holes in the wall with a depth of 45-50mm using the electrical drill, install expansion bolts in the holes and secure the high voltage box to the wall with a proper hammer.

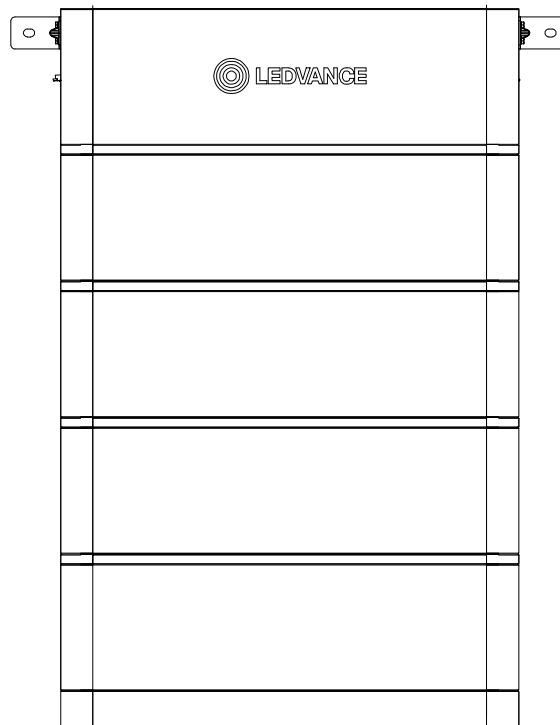

INSTALLATION

Selection of installation sites

The installation location is recommended to meet the size requirements of the figure below :

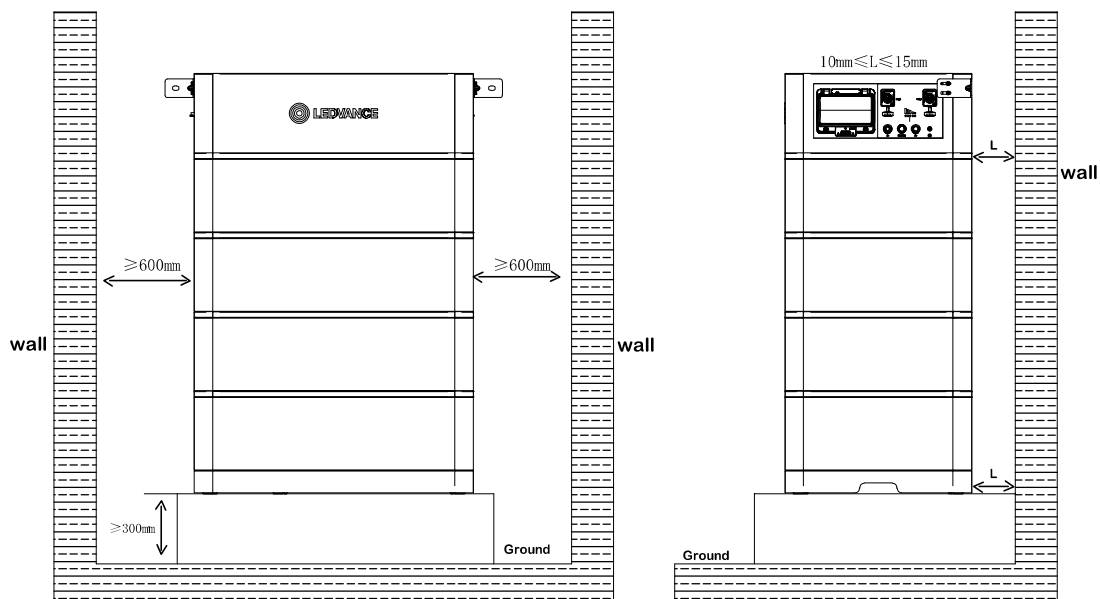

Definition of Interface

Link_1		Link_2		Link_3
DI1_L	1	DC24V-	1	DC24V-
/	2	ADDR_DI	2	ADDR_DO
/	3	CAN2_S	3	CAN2_S
CAN3_H	4	CAN2_H	4	CAN2_H
CAN3_L	5	CAN2_L	5	CAN2_L
/	6		6	
RS485_1A	7		7	
RS485_1B	8		8	

INSTALLATION

Batteries in parallel



- ① If the combiner box is not used, the parallel connection device should meet the following requirements.
 - a) No less than IP 55 for the outdoor use.
 - b) Maximum Operating Voltage, 700V DC
 - c) Maximum Output Current, 40A DC
 - d) Breaking Current, 50A DC.
- ② The total power cable length between each battery cluster and the inverter should be less than 10 meters.

Single Battery System

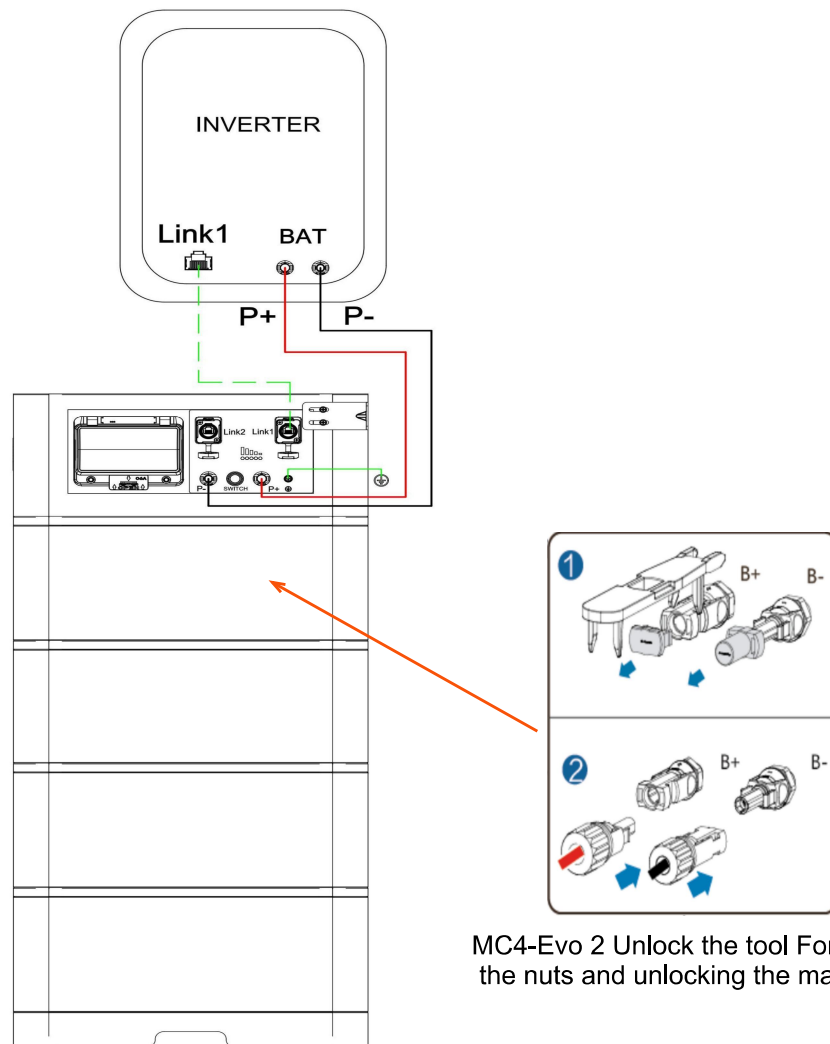

If it is failed to switch on the battery system.

CONTACT OUR LOCAL AFTER-SALE SERVICE WITHIN 48 HOURS.

COMMISSIONING

Switch on the Battery System

Requirements:

- The battery and the inverter must be properly installed and fixed.
- All cables must be correctly connected.

Steps:

- ① Turn the external protection switch between the high voltage box and the inverter from OFF to ON.
- ② Turn the high voltage isolation switch of the high voltage box from OFF to ON.
- ③ After startup, the system enters the self-check mode, The green LED is lit, and the light state corresponds to the current SOC power. Without other light indication, the battery system enters the high-voltage standby mode and can work normally.
- ④ If the battery pack is connected in the "ready" state after the inverter, and cannot normally power on normally, at this time, you can press the Black start switch for more than ten seconds, the state becomes "high voltage standby", force the power on.

Note: Black start switch

Except special circumstances after consultation with the manufacturer.

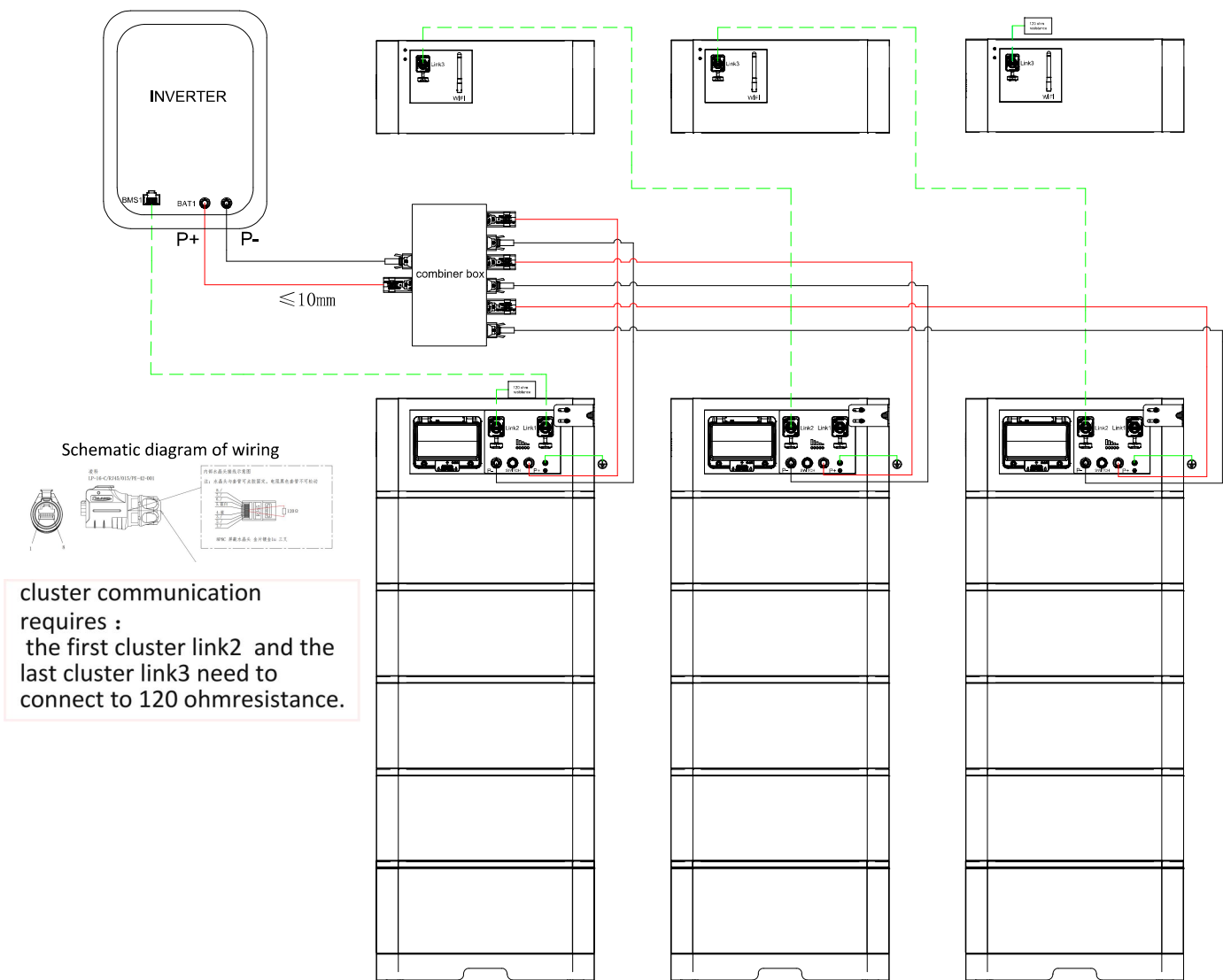

Each cluster is connected to the junction box corresponding connector, The junction box is provided by the battery supplier. The confluence bus is installed by customers.

COMMISSIONING

Instructions for the use of the parallel clustering:

1. Installation requirements and installation precautions refer to the product instructions in detail.
2. Power sequence of the cluster system: close all the empty opening of the cluster ,and then close the empty opening of the main cluster.
3. The voltage difference between clusters is within 5V and can be normal and cluster successfully.
4. Before cluster level connection,ensure that each single cluster system triggers no alarm,otherwise the cluster will not succeed.
5. The DC bus should meet the maximum output voltage and current requirements, otherwise it will cause overload heating.
6. The correct connection terminals must be used.

Light meaning

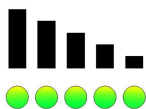
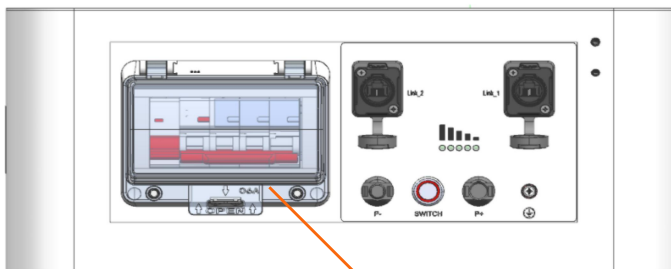

Note:
After successful power-on,cover the protective cover and tighten the nuts at both ends to keep the HV DC switch in the IP65 protective state.

Greenx5 show SOC

	One green light indicates the remaining 20% SOC
	Two green lights indicate the remaining 40% SOC
	Three green lights indicate the remaining 60% SOC
	Four green lights indicate the remaining 80% SOC
	five green lights indicate the power of 100% SOC NOTE:When the system does not trigger the primary or secondary protection, all 5 LED indicators are used as SOC status indication. When the primary protection is triggered, 5 LED slow flash (0.5s light, 2s out), and 5 secondary protection LED flash (0.5s on, 0.5s out)

COMMISSIONING

explain:

Because the high voltage box of the energy storage system is separated from the battery module before installation, SOC may deviate after the first installation, so it is necessary to connect the inverter for charging calibration after installation. Generally, after the battery is fully charged, BMS will calibrate the SOC through the power learning.

Battery forced charging function:

When the battery establishes normal communication and charge and discharge connection, the battery is in the discharge state. When the discharge SOC is less than 10%, the battery forced charging function is triggered until 20% ends the strong charging, and switch to the normal working state.

Switch off the Battery System

Steps:

- ① Turn the high voltage isolation switch of the high voltage box from ON to OFF.
- ② Turn the external protection switch between the high voltage box and the inverter from ON to OFF. If two or three battery systems are connected in parallel, please firstly switch off the first battery which has a communication connection to the inverter, and then switch off all the other batteries.

SAFETY DESIGN

- 1.The battery system cannot be turned on if the battery is incomplete or is not installed properly.
- 2.The system will automatically shut down if the battery does not communicate with the inverter for 24 hours.
- 3.The system will automatically shut down if the battery or inverter installation error occurs for 10 minutes.
- 4.The system will automatically shut down if the voltage is too low within 60 seconds.

Electrical Schematic Diagram

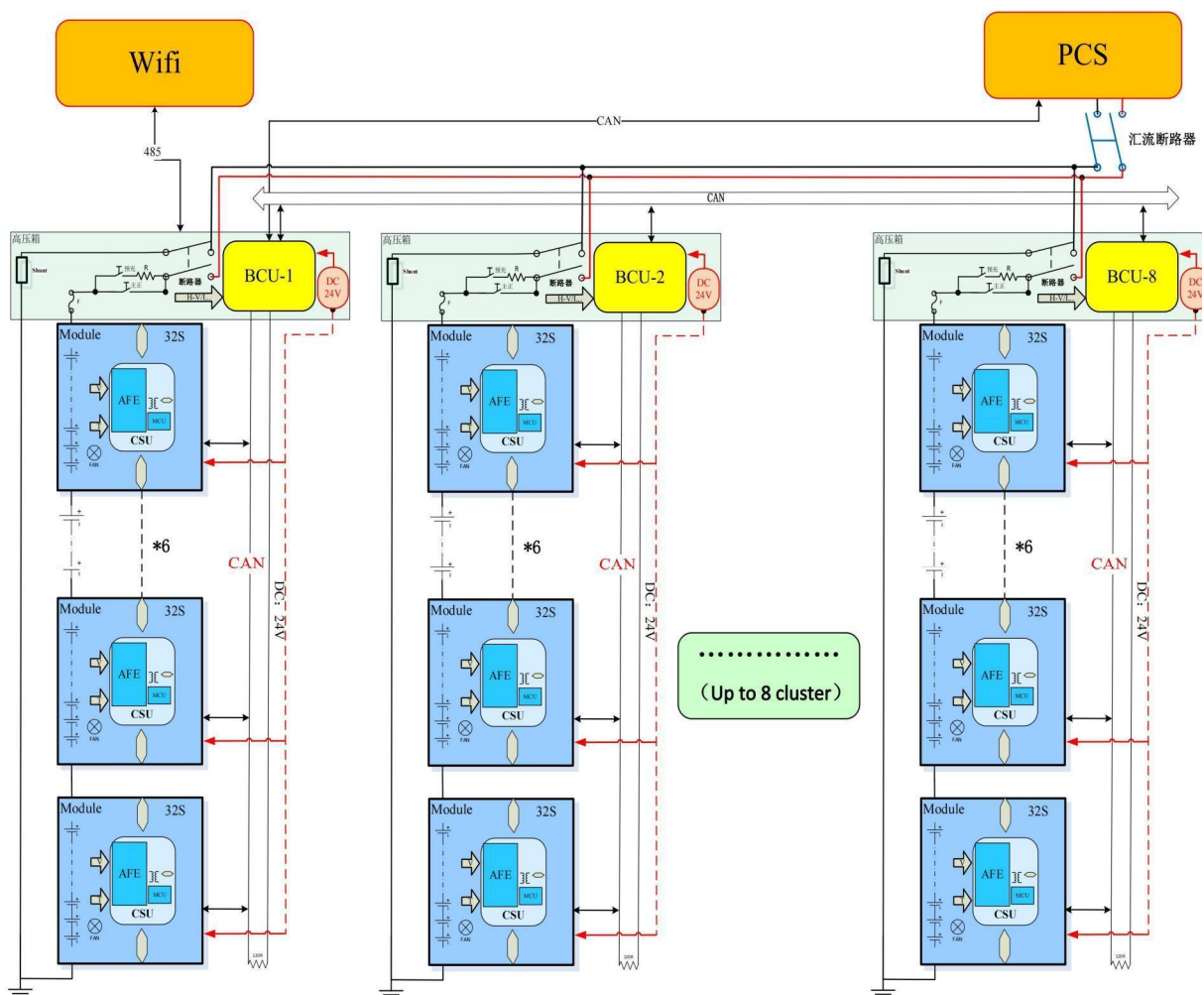

Wi-Fi DISTRIBUTION NETWORK

purpose:

The purpose is to describe how to use LEDVANCE RE App to network for the collector.

Instructions for using the Wi-Fi distribution network

Download the following APP to register the distribution network respectively



LEDVANCE RE

Scan the QR code below to download the LEDVANCE RE APP and register first.



Download is complete to enter the registration, follow the instructions to complete the corresponding registration.

Wi-Fi DISTRIBUTION NETWORK

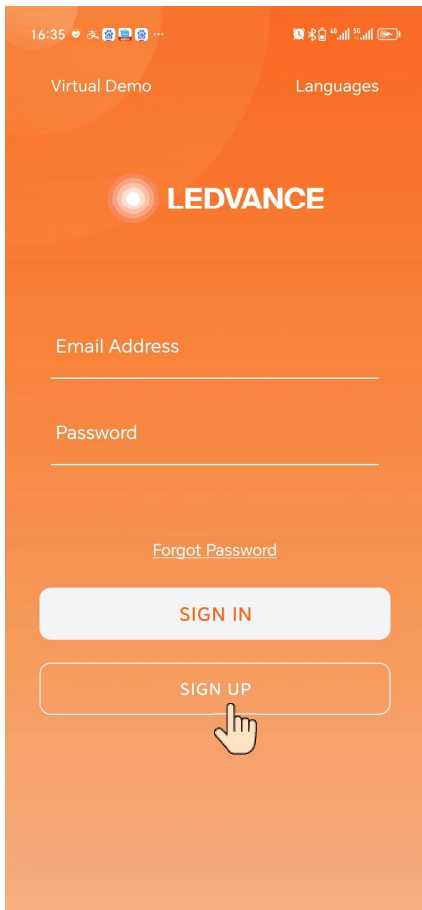

1. Click to register

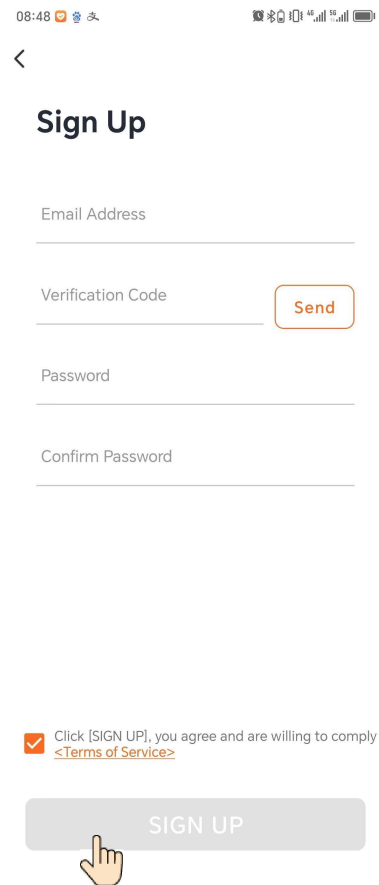

2. Fill in the registration information

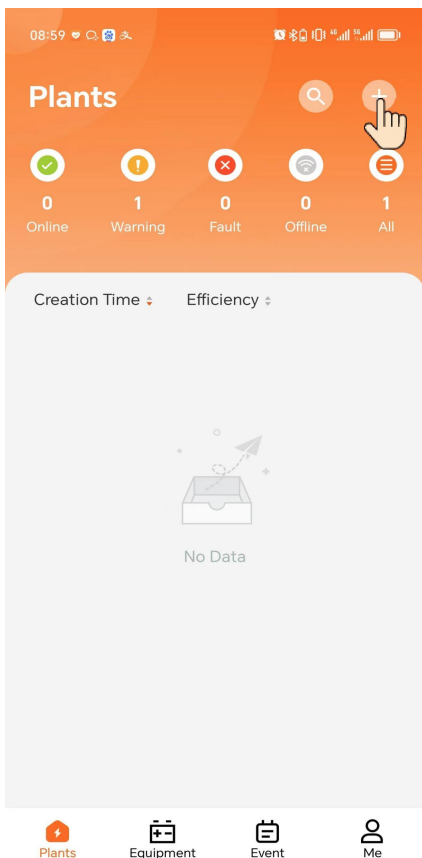

3. Click on the tracing QR code to establish the power station

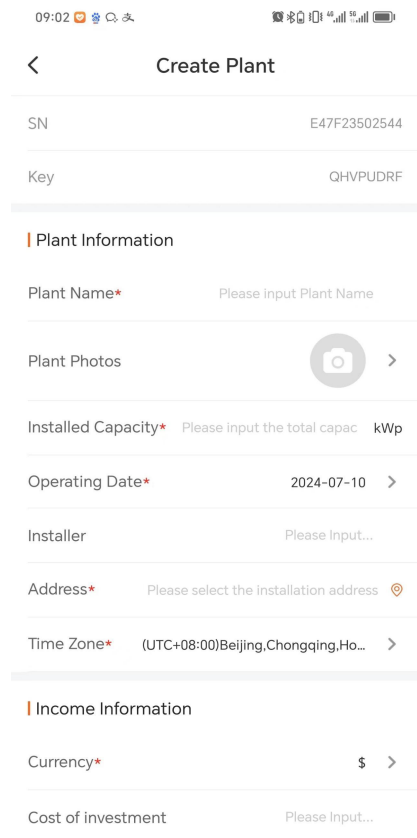

4. Fill in the power station information to create the power station

Wi-Fi DISTRIBUTION NETWORK



5. Click on the power station to enter the overview interface

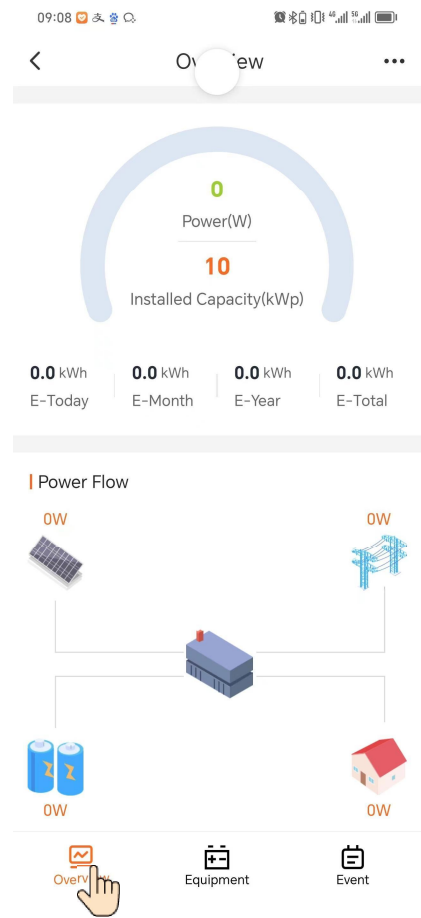

6. click Equipment

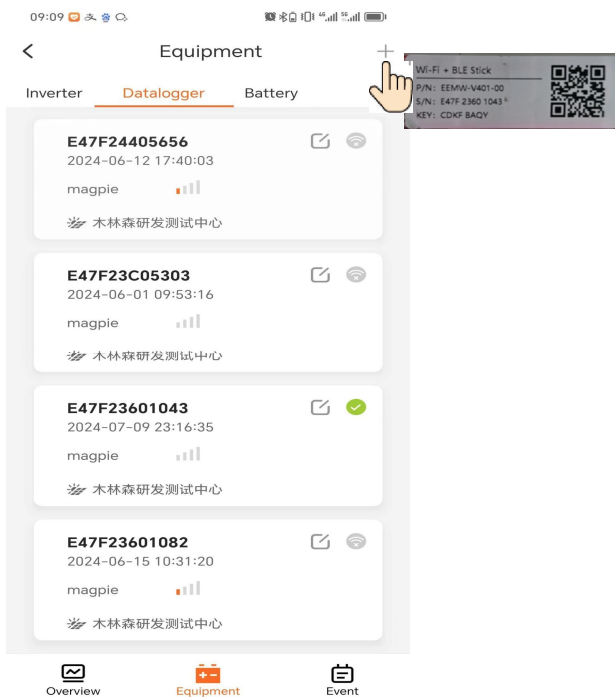

7. Click scan the QR code to add the collector. After the collector is successfully added, the WIFI signal lights up into a green flag

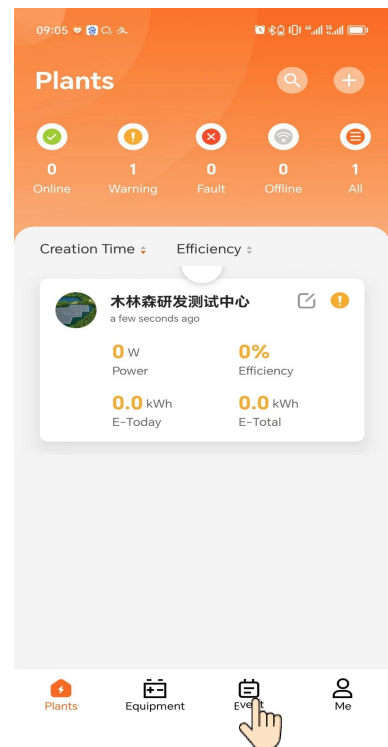

8. Return to the power station interface, click individual to enter the distribution network operation

WI-FI DISTRIBUTION NETWORK

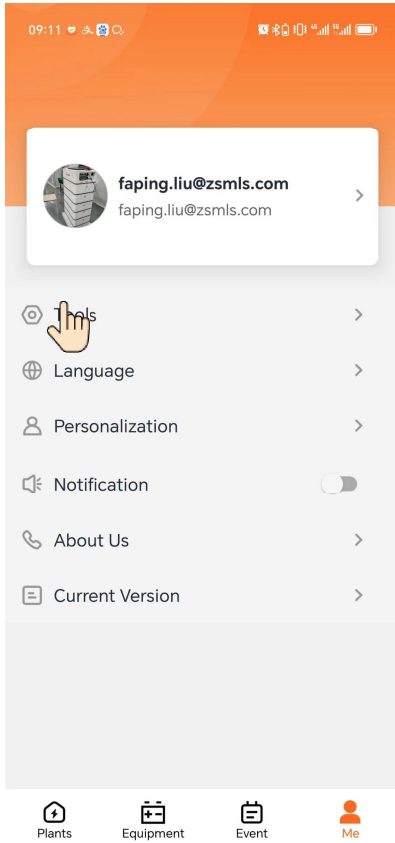

9. Click Tools

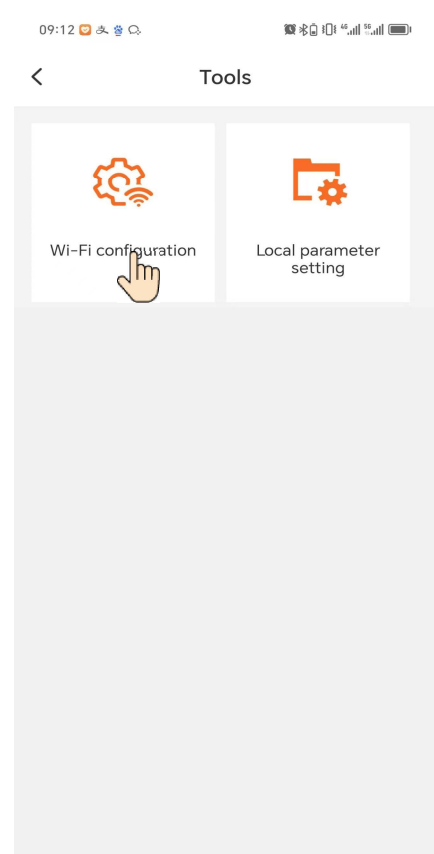

10. Click The WI-FI network configuration

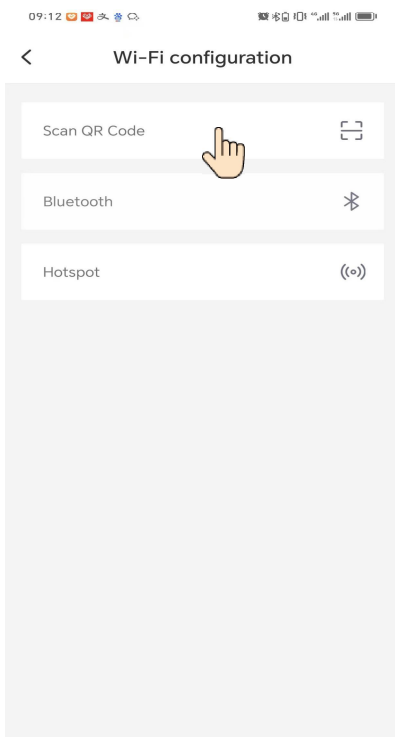

11. Click to scan the QR code of the equipment for the distribution network

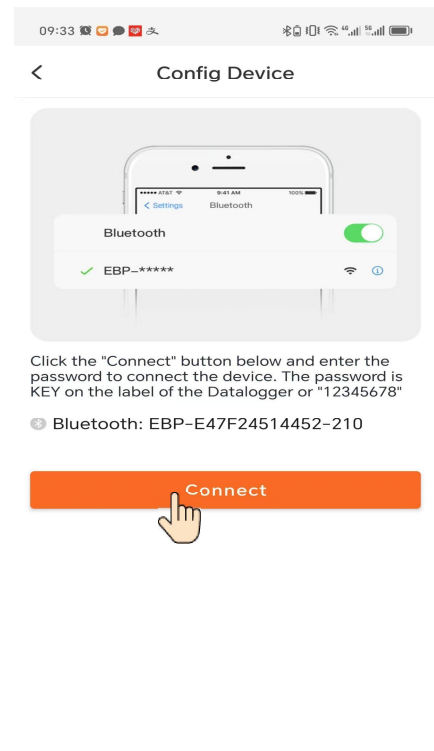

12. Click on Connect and enter the password: 123456

Wi-Fi DISTRIBUTION NETWORK

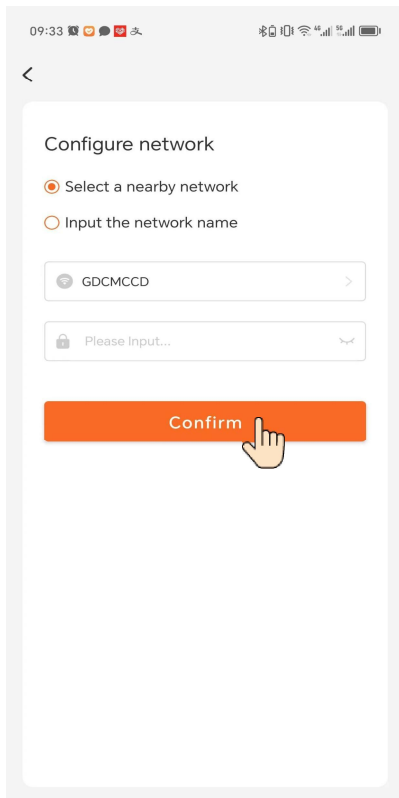

13. Select the router that the collector needs to be connected to the router, and enter the password of the router networking. After completion, click OK, and the successful distribution network interface will pop up



14. After the distribution network is successful, return to the power station interface and click the created power station

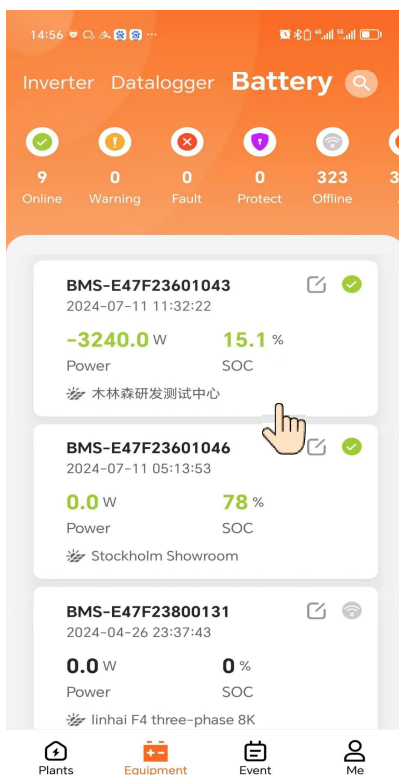

15. Enter the overview interface, click the device item and then click the battery bar, and enter the data viewing interface

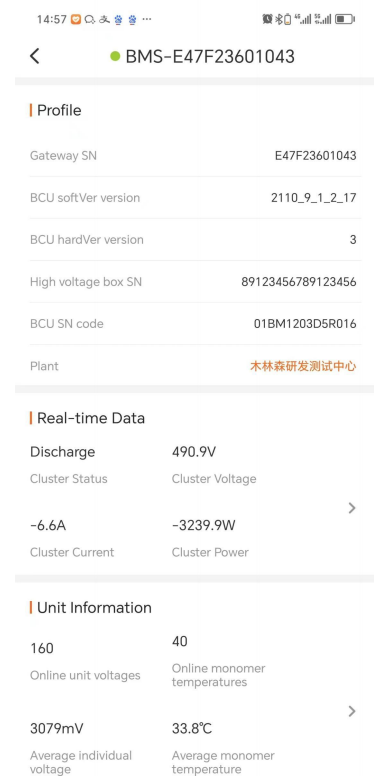

16. Data display interface, view the product SN, battery information and fault information

MAINTENANCE AND STORAGE

Cleaning

We recommend to clean the battery system regularly. If the battery housing is dirty, use a soft dry brush or dust collector to remove the dust. Do not use solvents, abrasives, or corrosive liquids to clean the housing.

During the maintenance of system cleaning, electrical connection, grounding reliability maintenance, etc, Perform the system down operation.

scope of examination	Check the method	Maintenance cycle
System running state	<ul style="list-style-type: none"> • Observe whether the appearance of the energy storage is damaged or deformed. • Listen to whether there is any abnormal sound in the energy storage during the operation. • When the energy storage is running, check whether the energy storage parameters are set correctly. 	Once every six months.
Electrical connection	<ul style="list-style-type: none"> • Check whether the cable connection is falling off and is loose. • Check whether the cable is damaged, focusing on whether the skin of the cable in contact with the metal surface is cut. • Check whether the unused DC input terminal, energy storage terminal, COM interface and waterproof cover are in a locked state. 	Half a year after the first test, and once every six months to once a year after that.
Ground reliability	Check whether the grounding cable is reliably grounded.	Half a year after the first test, and once every six months to once a year after that.

MAINTENANCE AND STORAGE

Storage

Storage environment

1. The storage environment shall meet the requirements of the local regulations and standards.
2. Store in a clean, dry and ventilated place, and prevent the erosion of dust and water vapor. Never allow rain or ground area water erosion.
3. The battery is stored indoors, without direct sunlight or rain, dry and ventilated, the surrounding environment is clean, there is no large number of infrared and other radiation, no organic solvent or corrosion gas, no metal conductive dust, far away from the heat source and combustion source.
4. If the battery fails (carbonization, leakage, expansion, water, etc.), it must be timely transferred to the dangerous goods warehouse for separate storage, not less than 3m away from the surrounding combustible materials, and scrap it as soon as possible.
5. When battery storage, it should be correctly placed according to the packing box mark. It is strictly prohibited to place back, side, tilt and stack time. Close the stacking requirements on the outer package.
6. When battery storage, please store separately to avoid mixing with other equipment and avoid battery stacking too high. On-site storage: When putting more batteries, it is recommended to have fire fighting facilities that meet the requirements, such as fire sand and fire extinguishers.

ATTENTION

1. During the battery storage, it must be disconnected from the external connection. If the battery panel has an indicator light, the indicator light should be extinguished.
2. During the storage period, relevant certificates that meet the product storage requirements, such as temperature and humidity log data, and storage rings, photos and inspection reports, etc.
3. When shipping batteries, the first-in, first-out principle should be followed.
4. The storage time should be calculated from the latest charging time on the battery packaging, and the latest one should be updated after charging. Secondary charging time.

Storage environment temperature	Relative humidity of the storage environment	Storage time	SOC
Below -10°C	/	Not allowed	/
-10-25°C	5%-80%	≤12 months	SOC≥50%
25-35°C	5%-80%	≤9 months	SOC≥50%
35-50°C	5%-80%	≤6 months	SOC≥50%
Above 50°C	/	Not allowed	/

Note: To ensure the battery service life, keep the storage temperature of the battery module between 0°C and 35°C.

MAINTENANCE AND STORAGE

Overtime storage

1. After the battery production test is completed, at least 50% SOC should be added before storage.
2. When shipping the stored batteries, the first-in-first-out principle should be followed.
3. Battery is recommended to be used in time. For long-term batteries, please conduct regular power supplement treatment, otherwise it may lead to electricity Pool damage.
4. The warehouse manager shall make statistics on the battery storage situation every month, and regularly report the battery inventory situation to the planning link, for Storage time is close to 12 months ($-10^{\circ}\text{C} \sim 25^{\circ}\text{C}$), 9 months ($25^{\circ}\text{C} \sim 35^{\circ}\text{C}$), or 6 months ($35^{\circ}\text{C} \sim 50^{\circ}\text{C}$) battery, timely arrangement supplementary power.

Storage temperature requirements	Actual storage temperature	Supplemental electrical cycle	remarks
$-10^{\circ}\text{C} < T \leq 50^{\circ}\text{C}$	$T \leq -10^{\circ}\text{C}$	not allow	Supplement within the power cycle: no need to be treated, use as soon as possible
	$-10^{\circ}\text{C} < T \leq 25^{\circ}\text{C}$	12 Months	
	$25^{\circ}\text{C} < T \leq 35^{\circ}\text{C}$	9 months	Time to reach supplementary power: supplementary power treatment
	$35^{\circ}\text{C} < T \leq 50^{\circ}\text{C}$	6 months	
	$50^{\circ}\text{C} < T$	not allow	

Excessive time storage judgment condition

In principle, it is not recommended to store batteries for a long time. Long-time deep discharge will cause battery damage, and it should be used in time. For overdue storage, professionals should be checked and tested before being put into use. The stored batteries should be processed according to the following requirements.

1. The battery is deformed, damaged, leaked, and directly scrapped without considering the storage time.
2. Storage time Take the latest charging time on the battery package as the starting point for the battery After the supplementary power, refresh the latest charging time and next charging time (next charging time = recent charging time + recharge cycle).
3. The maximum allowable period and times of storage and supplementary power is 3 years or 3 times, exceeding the maximum allowable period and times of the recommended battery announce invalidated check in paper.
4. There will be capacity loss in the long-term storage of lithium battery, and the longer the long-term storage time, the greater the capacity loss will be. If the customer Conduct discharge test and acceptance according to the specification, for batteries with storage capacity less than 100% rated capacity, exist The risk of failing the test.

MAINTENANCE AND STORAGE

Pre-battery recharge test

1. The battery should be inspected for the appearance before the battery replenishment, and the qualified battery can be supplemented in the next step Electrical treatment, unqualified battery scrap treatment.
2. If the battery has the circumstances listed below, it will be judged to fail the appearance inspection.-
Reformation of eggplant battery
-Battery case is broken
-Diacyl cell leakage

Battery low power replenishment requirements

After the battery is down, there is static power consumption of the internal module of the battery, so the low power state of the battery should be avoided Storage, you need to fill the battery in time, otherwise the battery may be damaged due to overdischarge, and the battery mode needs to be replaced block.

Scenarios that may trigger low power storage, including but not limited to:

1. The DC switch (DC SWITCH) on the power control module is not turned on.
2. Battery power line or signal line is not connected.
3. After the energy storage discharge, it cannot enter the charging state due to system failure.
4. The system does not correctly add or configure the energy storage, so that the battery cannot enter the charging state.
5. No PV input and the power grid drops the power for a long time, so that the battery cannot enter the charging state.

Regardless of the low-power storage scenario, it must follow the maximum interval allowed by the SOC when the battery is fully powered down Line to fill electricity. If the battery is not replenished after the maximum interval, the battery may be damaged due to overdischarge.

SOC when down before storage	Maximum recharge interval time
SOC \geq 5%	15 Days
0 \leq SOC<5%	7 Days

explain

1. When the battery SOC is reduced to 0%, it should be replenished within 7 days. Permanent battery due to customer reasons Fault, the company does not provide the corresponding warranty service.
2. When the battery SOC is low due to its own loss or long-term storage uncharging, in order to prevent the battery from being damaged due to overdischarge Bad, the system will force the battery to power.

DISPOSAL

recovery processing

1. Please dispose of the waste batteries according to local laws and regulations. Do not use the batteries as household waste. Improper disposal of batteries could lead to environmental pollution or an explosion.
2. In case of any battery leakage or damage, please contact the technical support or battery recycling company for scrapping.
3. When the battery is not available beyond its service life, please contact the battery recycling company for scrapping treatment.
4. Avoid exposing waste batteries to high temperatures or direct sunlight.
5. Avoid exposure of waste batteries to high humidity or corrosive environments.
6. The faulty battery is forbidden to be used twice. Please contact the battery recycling company as soon as possible to avoid environmental pollution.

Attention:

1. Do not dispose of batteries and rechargeable batteries as domestic waste!
You are legally obliged to return used batteries and rechargeable batteries.
2. Waste batteries may contain pollutants that can damage the environment or your health if improperly stored or handled.
3. Batteries also contain iron, lithium and other important raw materials, which can be recycled.

Do not dispose of batteries as household waste!



Corporate name: LEDVANCE GmbH
Company address: Steinerne Furt
6286167 Augsburg Germany
Contact Information: Krzysztof Rytel
+48 734 134 386 k.rytel@ledvance.com

Fault and solution

APP event alarm and uer machine fault control table

ID	upper monitor -EN Desp.	APP-EN Desp.	APP-Display Code	fault treatment
1	CELL_OV	Individual voltage too high	F1	Stop charging and recover after the voltage drops to the difference value
2	CELL_UV	Single cell voltage too low	F2	Stop the discharge and recover after the voltage rises to the return value
3	CELL_DV	Excessive voltage difference between individual cells	F3	Equalize function recovery through the system
4	BATT_OV	Total voltage too high	F4	Stop charging and recover after the voltage drops to the difference value
5	BATT_UV	Total voltage too low	F5	Stop the discharge and recover after the voltage rises to the return value
6	CELL_DSCH_OT	Battery discharge temperature too high	F6	Recovery after the temperature is reduced to the return value
7	CELL_DSCH_UT	Battery discharge temperature too low	F7	Recovery after the temperature rises to the return value
8	CELL_CHRG_OT	Battery charging temperature too high	F8	Recovery after the temperature is reduced to the return value
9	CELL_CHRG_UT	Battery charging temperature too low	F9	Recovery after the temperature rises to the return value
10	CELL_DT	Single body temperature difference too large	F10	Recovery after the temperature is reduced to the return value
11	CHRG_OC	Charging current too high	F11	Reduce the charging current and recover after the current is reduced to the return difference value
12	DSCH_OC	Discharge current too high	F12	Reduce the discharge current and recover after the current is reduced to the return difference value
13	CHRG_OP	Charging power exceeding limit	F13	Reduce the charging power,and recover after the power is reduced to the return difference value
14	DSCH_OP	Discharge power exceeding limit	F14	Reduce the discharge power and recover after the power is reduced to the return difference value

Fault and solution

15	PWR_OV	BMS power supply voltage high	F15	1.Restart the battery recovery 2.If the contact with technicians cannot be restored after the restart
16	PWR_UV	BMS power supply voltage low	F16	1.Restart the battery recovery 2.If the contact with technicians cannot be restored after the restart
17	BATT_OC	Battery pack SOC too high	F17	The battery is set to the discharge state to recover
18	BATT_UC	Battery pack SOC too low	F18	The battery can be restored by setting it to the charging state
19	BATT_UH	Battery pack SOH too low	F19	Contact the technician for an analysis
20	INSU_FAULT	Insulation fault	F20	1.Check the ground wire connection 2.If it cannot be excluded,contact the technician for analysis
21	CAN_BUS_OFF	CAN BUS OFF	F21	1.Check whether the high voltage box is in good contact with the battery module,and then restart the battery recovery 2.If the technical contact cannot be restored after the restart
22	COM_OFFLINE	Internal communication failure	F22	1.Check whether the module and the high-voltage box are well stacked 2.If the technical contact cannot be restored after the restart
23	RELAY_MPOS_FAULT_	Main positive relay malfunction	F23	Contact the technician for an analysis
24	RELAY_MNEG_FAULT	Total negative relay failure	F24	Contact the technician for an analysis
25	RELAY_FCHRG_FAULT	Fast charging relay malfunction	F25	The high pressure box does not have this function and can be ignored
26	RELAY_SCHRG_FAULT	Slow charging relay malfunction	F26	The high pressure box does not have this function and can be ignored
27	RELAY_HEAT_FAULT	Heating relay malfunction	F27	Contact the technician for an analysis
28	RELAY_LIFE_END	Relay lifespan too low	F28	Contact the technician for an analysis
29	PRECHRG_FAIL	Precharge failed	F29	Contact the technician for an analysis

Fault and solution

30	THERMAL_RUN AWAY	Thermal runaway fault	F30	<p>1. Check whether the high voltage box is in good contact with the battery module, and then restart the battery recovery</p> <p>2. If the technical contact cannot be restored after the restart</p>
31	COLLISION	Collision protection	F31	The high pressure box does not have this function and can be ignored
32	HVIL_FAULT	High voltage interlock fault	F32	<p>1. Check whether the high voltage box is in good contact with the battery module, and then restart the battery recovery</p> <p>2. If the technical contact cannot be restored after the restart</p>
33	SCHRG_GUN_FAULT	Slow charging gun malfunction	F33	The high pressure box does not have this function and can be ignored
34	FCHRG_GUN_FAULT	Fast charging gun malfunction	F34	The high pressure box does not have this function and can be ignored
35	CELL_VOLT_FAULT	Single cell voltage fault	F35	Contact the technician for an analysis
36	CELL_TEMP_FAULT	Individual temperature fault	F36	Contact the technician for an analysis
37	CURR_SENSEN_FAULT	Current sensor malfunction	F37	Contact the technician for an analysis
38	BMS_FAULT	BMS malfunction	F38	Contact the technician for an analysis
39	SBC_FAULT	SBC chip malfunction	F39	Contact the technician for an analysis
40	AFE_FAULT	AFE chip malfunction	F40	Contact the technician for an analysis
41	BALANCE_FAULT	Balanced circuit failure	F41	Contact the technician for an analysis
42	MCU_FAULT	MCU chip failure	F42	Contact the technician for an analysis
43	BMS_INTERNAL_FAULT	Internal fault	F43	Contact the technician for an analysis
44	ALM ID TEMPRISE FAULT	Temperature rise fault	F44	Check the temperature of the battery charge and discharge process, if there is no abnormal recovery, and repeat the fault, contact the technician for analysis

Note:

1. The restart battery refers to the disconnection, close the power, open the air and close the time interval to avoid too short, generally the interval of about 3S closed again.
2. If the battery failure can not be cleared for many times, please disconnect the battery to power on, and contact the technical personnel for analysis and solution in time.